

Aufbauanleitung / *assembly instructions* mod. **1630 - 1633 Metallfuß, fest**

(L: 140 & 190 cm)

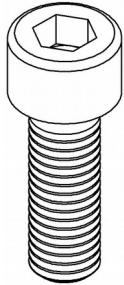

8x
M10 x 30

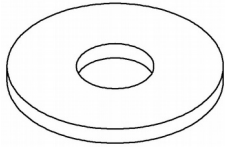

8x
30 x 10,5

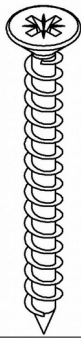

12x
4,5 x 45

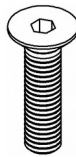

8x
M5 x 20

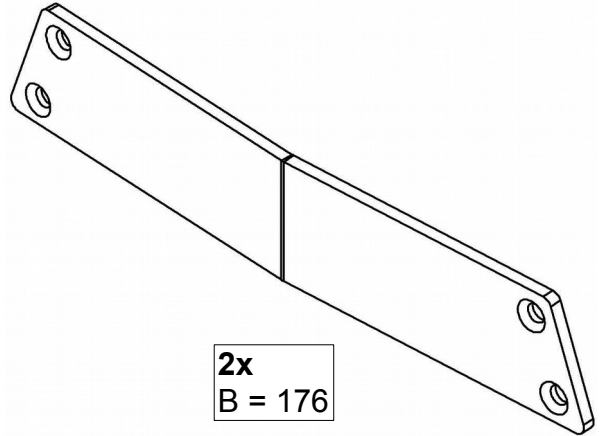

2x
B = 176

1. Montagematerial.
2. *Fitting material.*



2. Die Sperrholz-Platte umgedreht auf gepolsterten Montageböcken ablegen.
2. *Put the table-top upside down onto padded assembling trestles.*

Mod. 1630 (L = 140 cm) & 1632 (L = 190 cm):

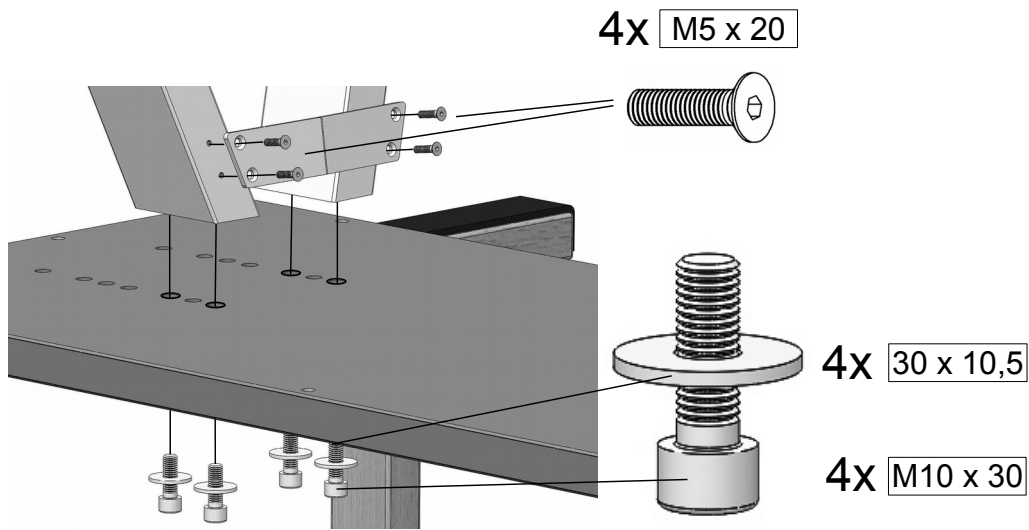

Mod. 1631 (L = 160 cm) & 1633 (L = 220 cm):

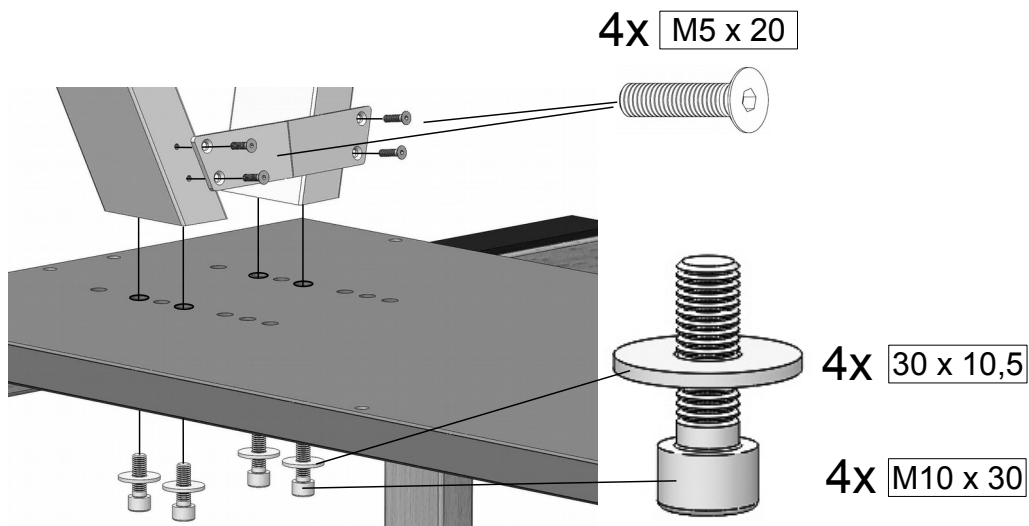

3. Die Bolzen der Tischbeine in die im Bild gezeigten Löcher stecken. Jeden Bolzen mit einer Unterlegscheibe und einer Mutter fixieren.
Die Schrauben des Verstärkungsblechs in die Gewinde der Metallbeine schrauben.
3. *Stick the bolts of the table legs into the holes which are shown in the picture above. Fix each bolt with a washer and a nut.
Fix each reinforcing plate with 4 screws.*

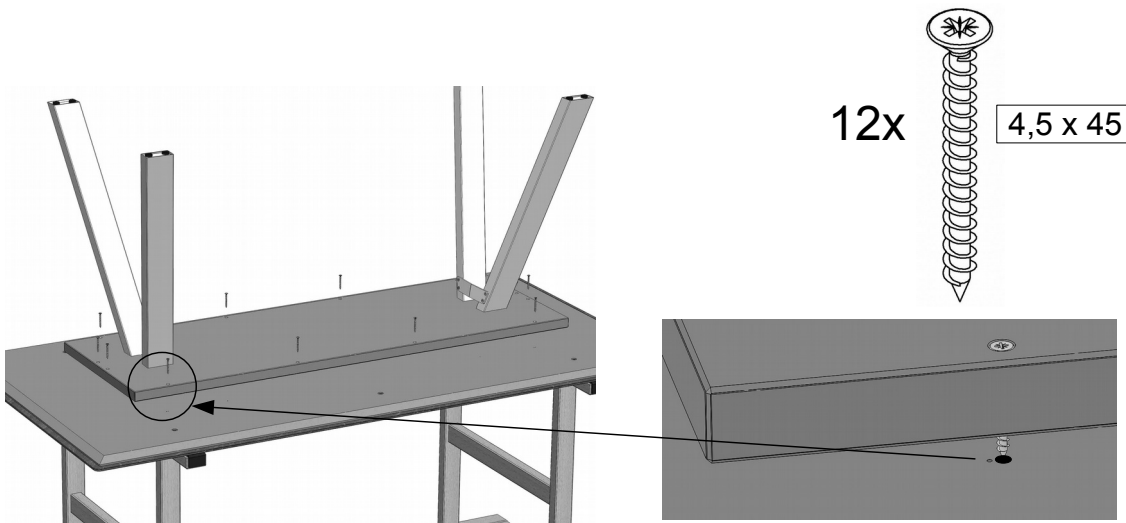

4. Beim Anschrauben der Sperrholz-Platte des vormontierten Unterbaus die Markierungs-Bohrungen nutzen.
4. *Screw on the plywood-plate of the pre-assembled table base to the table top and use the marking holes.*

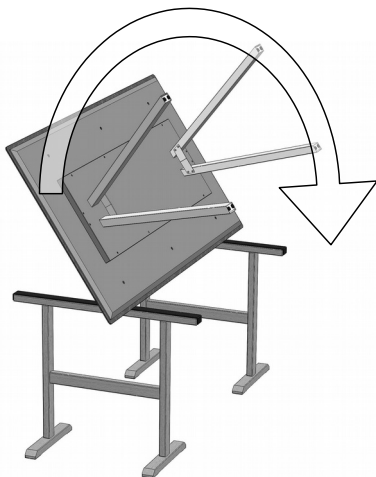

5. Den Tisch wenden ohne die FüÙe zu belasten ...
5. *While turning the table the feet must not touch the ground ...*



6. ... und dann gleichzeitig alle 4 Tischbeine auf dem Boden absetzen.
- Fertig.**
6. *... and then put all the 4 table-legs onto the floor at once.*
- Ready.**